

Operation manual for SESAM folding partitions

General

The folding partition consists of a number of panels which are connected to each other with hinges. The last panel works as a pass door. At the other end is the wall panel. The folding partition runs in a floor track and a top track.

To make it run smoothly make sure these tracks are free from any obstruction.

If the folding partition runs as a two-wing-set, then one of the meeting panels operates as a closing-jamb-panel. The

pass door panel has a latch-lock and a lever handle on one side and a recessed D-ring handle on the other side. On the lower outer corner of the pass door panel (also closing-jamb-panels if two-wing-set) a magnet is installed. The keeper for

the magnet is installed on the panel before.

Some panels have an integrated floor locking device installed to fix the partition in the closed position, it is operated by a special key supplied.

Open

1. Open the pass door 180° so it locates with the magnet that keeps it in position.

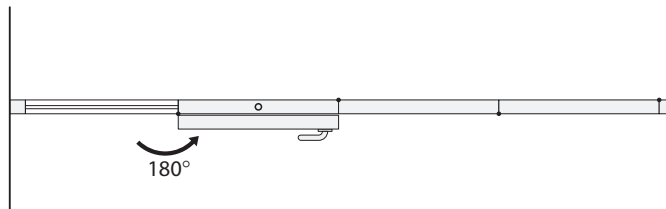

2. Open the floor locking device with the special key.

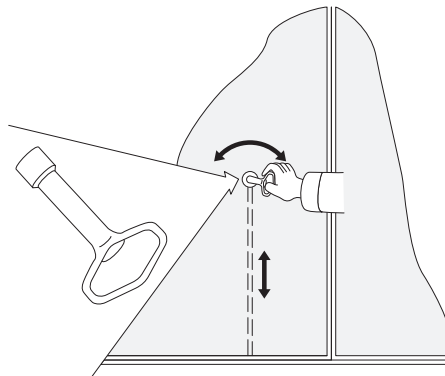

3. Start to open the partition by pressing on each joint with visible hinges. Start at the wall panel and work towards the pass door.

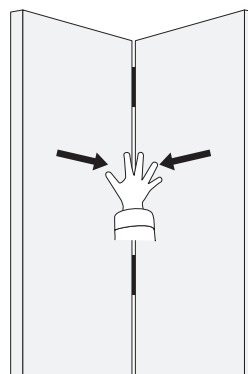

Continued over leaf

4. Turn the pass door and the connected panel so they are at a right angle to the track.
5. Push the pass door in the direction of the wall panel so the partition is folded in the parked position.
6. If the folding partition is a two-wing-set repeat point 1-5 for the second wing.

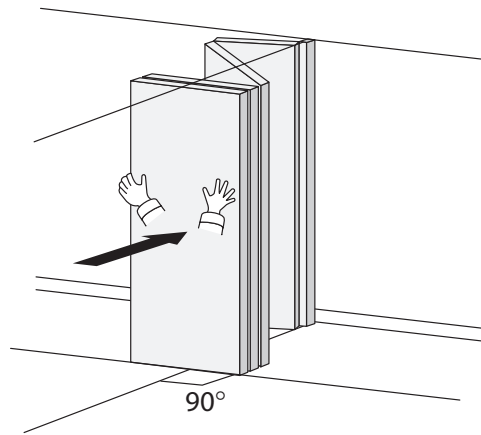

Note If the folding partition gets caught before it arrives in the parking position simply move the pass door and the panels connected to it backwards a few inches and repeat point 3. After that continue with point 5.

Close

The outermost panel is the pass door and should be connected to the panel

next to it with the magnet. These two panels should be

connected to each other until you reach point 5. If the folding partition is a

two-wing-set, start with the wing that has the closing-jamb-panel.

1. Turn the pass door and its connected panel by pulling on the hinge side. Slightly push on the other side.

The pass door handles should not be used for pulling the panels.

Move the panels out on the floor. Continue to turn and pull until the two outermost panels are lining up with the track.

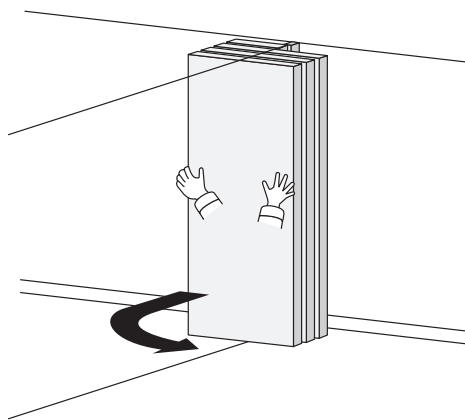

2. Push on the edge of the pass door where the lock is located, as shown in the illustration. Continue pushing the panels as far as they go.

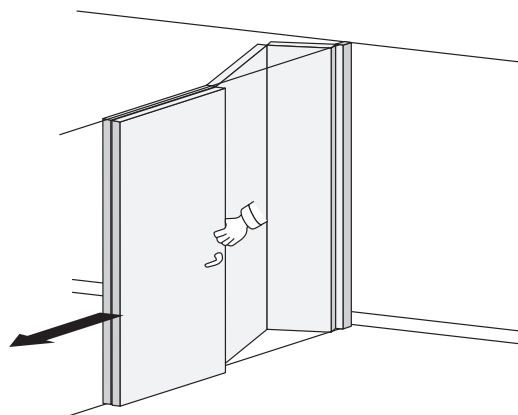

3. Flatten the partition by pushing at the panel joint, on the opposite side to the hinges. Be careful you don't squeeze your fingers between the panels. Work from the wall panel outwards to the pass door.

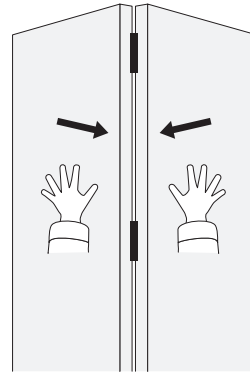

4. Fix the partition in place with the floor locking device. Ensure that the folding partition is flat and that the floor locking device locates into the track (or the keeper if available).

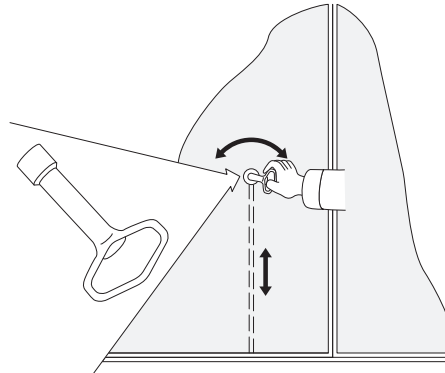

5. Close the pass door.

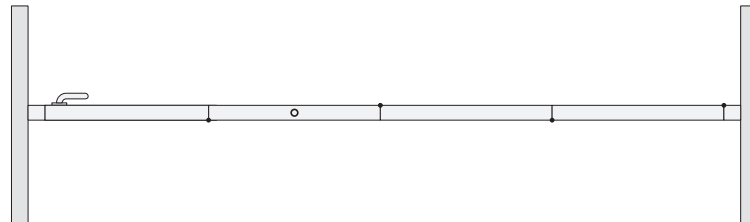

Never use FORCE to operate the folding partition.

If necessary contact your local dealer for service.





DIVIDERS FOLDING PARTITIONS LTD

Factory and Head Office

Unit 1, Llanelli Gate, Dafen, Llanelli, SA14 8LQ

t: 01554 754510 f: 01554 741863

e: sales@dividersfp.com

w: www.dividersfp.com

